

QSCControl.net Version 3

Networked control, transport, processing and monitoring – from source to loudspeaker.

Hear the Power of Technology



www.qscaudio.com

Phone: 1-800-854-4079 or 714-957-7100, Outside the U.S. 714-754-6175 / Fax: 714-754-6174
1675 MacArthur Boulevard, Costa Mesa, CA 92626

An elegant solution for simple to complex applications.



Perfect for both installed and portable live sound applications, including outdoor events, stadiums and arenas, casinos, cinemas, restaurants, hotels, retail establishments, houses of worship, corporate campuses and convention centers.

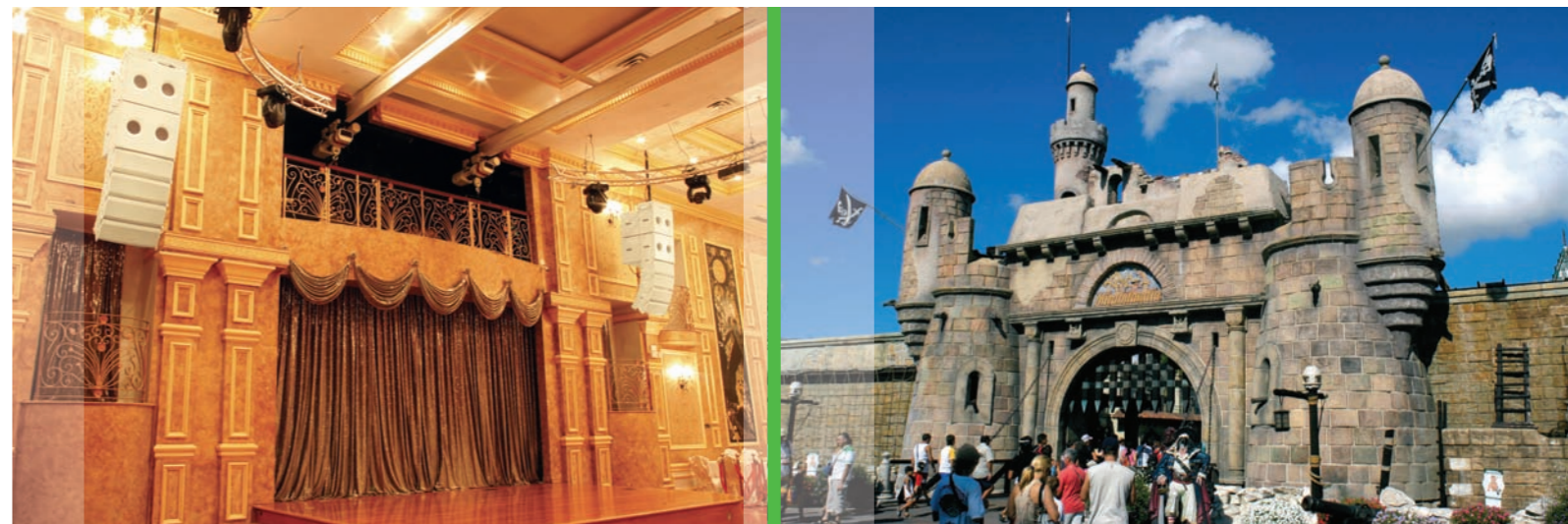

Manage your system from a single networked computer or from multiple networked computers simultaneously.

QSCControl.net has the fundamental ability to serve as an all-encompassing, networked audio system with a wide-sweeping reach extending from microphone input to loudspeaker output. Designed expressly for system integrators, contractors, consultants and audio engineers, this proprietary technology from QSC brings a new measure of unity to processing, amplifier management and audio transport functions

that can be easily integrated with QSC power amplifiers and loudspeakers.

Central among an ever-expanding cast of QSCControl.net enabled products are components built upon the BASIS hardware platform, as well as the current generation of QSC's RAVE units and DSP 322ua processors. With the exception of the BASIS 722az, all BASIS processors house amplifier and



loudspeaker management capabilities, configurable DSP and CobraNet™ digital audio transport functions. Like the BASIS devices, QSC RAVE and DSP 322ua units can be controlled by QSC's Venue Manager software. By definition, RAVE units offer both digital audio transport and DSP functions, while the DSP 322ua is a dedicated processing device only.

Ideally suited for applications both large and small, the power of QSCControl.net is a logical choice for stadiums, arenas, theatres, nightclubs, restaurants, hotels, houses of worship, corporate campuses, educational facilities and anywhere else a need exists for a powerful system-wide audio solution.

All of the functions found within the QSCControl.net platform can be controlled from a single networked computer or from multiple networked computers simultaneously. Armed with wireless laptops, multiple operators can even make adjustments to different parts of a QSCControl.net system concurrently and in real-time.

Integrated Technologies

Far more than digital processing, QSCControl.net encompasses a complete system including CX, PL3 and DCA series amplifiers as well as a growing range of loudspeaker systems including AcousticDesign™, WideLine, ILA, ModularDesign™ and DCS products.

QSCControl.net combines the three distinct QSC technologies of configurable DSP, amplifier/loudspeaker control and monitoring, and CobraNet audio transport into a single unified system. As noted earlier, QSCControl.net hardware devices (BASIS, RAVE and the DSP 322ua) include various elements of all these technologies.

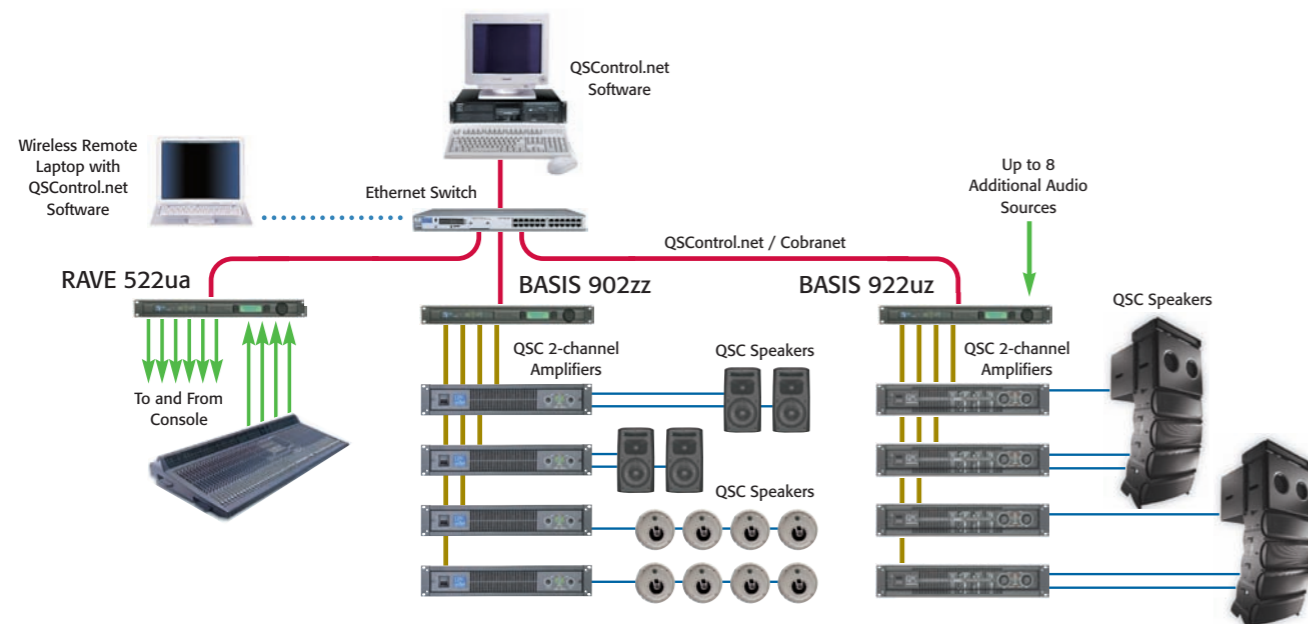

With Venue-Wide Design Mode, Auto Discovery of devices, and Global Presets, creating customized system management has never been better.

Processing screen shots shown below are left to right, top row: Filters, Crossover, Automixer, and Router. Bottom row: AGC, Matrix Mixer, Ducker and Macro.

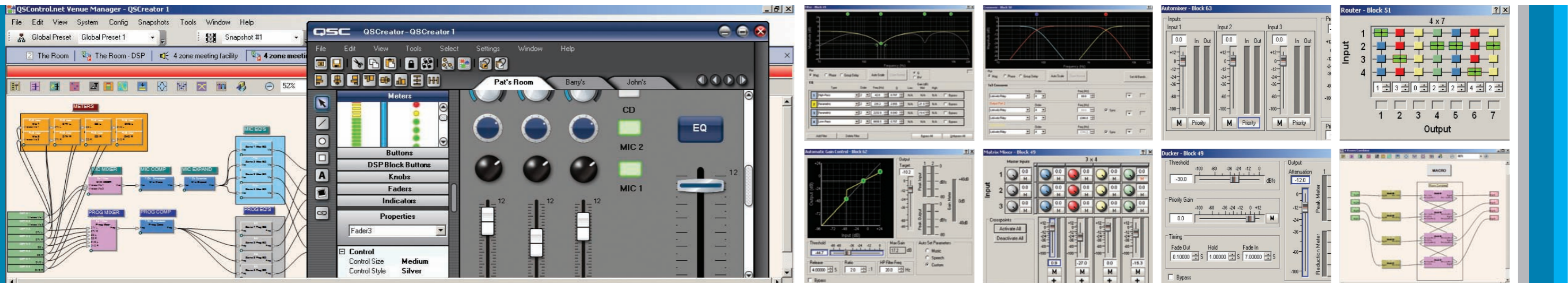

Venue Manager System-Wide Design Software

Venue Manager is QSCControl.net's drag-and-drop software. Providing access to real-time parameters for every device on the network, Venue Manager gives users the ability to monitor and build a log of system events, thereby making it easier to identify potential problems and stop them before they occur. Extensive system-wide features found within Venue Manager include:

Comprehensive Venue-Wide Design Functions

- Design and view an entire system offline without the need for hardware
- Load your entire system design into all of the online devices with a single mouse command
- Two modes: Design and Live (both look and feel identical)
 - Easily switch back and forth between the modes as often as you like
 - Update either mode with new settings via a single mouse click

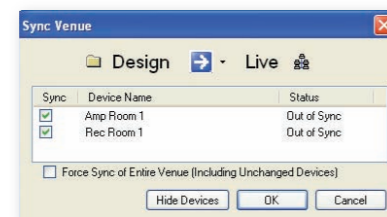

Auto-Discovery of Devices on the Network

- All of the devices on a network can be discovered with a single mouse click instead of entering each IP address manually

Global Presets

- A Global Preset is a collection of Configs, Snapshots, and Master Levels that can be recalled simultaneously across all devices
- Reconfigure an entire system with the click of a mouse
- Can include any number of parameters in the system (from one to all)
- Recall Global Presets from remote contact closures or logic signals
- Recall from front panel of BASIS

Masters

- Master Controls for the entire venue
- A single Master can access any number of similar slaves, from any number of devices

Archives

- Configurations that are saved to the Archives can be accessed from any Venue

QSCCreator Custom Control Panels

QSCCreator is hosted inside our Venue Manager system set up software to facilitate custom control panel creations. Control panels with a custom look and feel are designed by selecting from an extensive library of faders, knobs, buttons, meters, indicators and graphic tools. Once a control screen design has been developed, QSCCreator can be established as the only software required for system operations, preventing accidental adjustments or unauthorized tampering and keeping the control template as easy-to-use as possible.

A Wide Selection of Processing

An extensive selection of processing functions are found within the QSCControl.net platform, including:

Matrix Mixers

- Up to 24 Inputs and Outputs

Gain Sharing Automixing

- Facilitates any number of inputs up to 22
- Direct outputs available for every input
- A unique program reference input provides for automatic mic attenuation whenever program material is sensed

This latter feature is especially useful for applications such as meetings using several microphones, an automixer and multiple sources of program material (e.g., CD, DVD, etc.). With the program reference input, the volume of the microphones can be automatically attenuated to keep the other sources from bleeding into the system.

Routers

- Can accommodate any combination of inputs and outputs up to 24 x 24

Gain Controls

- Can accommodate any channel count up to 24

Graphic Equalizers

- Two Octave ISO
- One Octave ISO
- Two-Third ISO
- One-Third ISO
- Custom (choose number of bands, start frequency and end frequency)

Crossovers

- Linkwitz-Riley
- Butterworth
- Bessel-Thomson in-phase
- Bessel-Thomson symmetrical
- 2-way, 3-way and 4-way general purpose adjustable

Dynamics

- Compressor
- Peak limiter
- Dynamics processor
- Noise gate
- Automatic Gain Control – automatically boosts lower signal levels up to the user-defined target output level and reduces higher signal levels down to the user-defined target output level. Features three modes of operation: music, speech and custom.

Duckers

- Up to eight channels of audio can be simultaneously “ducked”. Fade-in and fade-out times can be up to 60 seconds each. The priority channel can also be part of the ducker's output mix.

Filters

- High-pass, low-pass, all-pass, shelf, parametric, parametric shelf, Butterworth high and low-pass, Bessel-Thomson high and low-pass

Delays

- Up to 910 mS
- Units measured in time, meters, feet

Pink Noise, White Noise, Sine Generators

Macros

- User-definable custom blocks with password protection

A wide dynamic range is extremely important to today's audio professional, and the Basis hardware delivers.

Model	Inputs			Outputs			Monitor I/O
	Analog	Digital	CobraNet	Analog	DataPort	CobraNet	
BASIS 722az	8 line level	-	-	-	4 (8 channels)	-	YES
BASIS 902zz	-	-	24 of 32	-	4 (8 channels)	32	YES
BASIS 904zz	-	-	24 of 32	-	8 (16 channels)	32	YES
BASIS 914lz	4 XLR line level	-	16 of 32	-	8 (16 channels)	32	-
BASIS 922az	8 line level	-	16 of 32	-	4 (8 channels)	32	YES
BASIS 922dz	-	25 pin AES/EBU (8 channels)	16 of 32	-	4 (8 channels)	32	YES
BASIS 922uz	8 universal mic/line	-	16 of 32	-	4 (8 channels)	32	YES
DSP 322ua	8 universal mic/line	-	-	8 line level	-	-	-
RAVE 520uz	8 universal mic/line	-	16 of 32	-	-	32	-
RAVE 522aa	8 line level	-	16 of 32	8 line level	-	32	-
RAVE 522ua	8 universal mic/line	-	16 of 32	8 line level	-	32	-

Wall E-Controller

- Color graphics display
- Power over Ethernet
- Recall Global Presets
- Rotary "wheel" control of masters
- Controllers can track each other
- Available color options black or white



QSC's BASIS, RAVE and DSP devices make up the family of QSCControl.net products, networked and controlled from Venue Manager software.

Eight unique signal flows can be stored in each QSCControl.net processing unit, and any of these can be accessed on the fly. Since these configurations are stored locally in the hardware, there is no need for a separate design file to make adjustments.

Users of most configurable DSP products are also undoubtedly familiar with the variable latency inherent in the processing configuration. Add more

processing blocks and you also add delay, whether you want it or not. The BASIS platform provides both short and fixed processing latency throughout its DSP subsystem, thereby ensuring that the total processing time between analog in and analog out within a single device measures less than 2.5 milliseconds.

A wide dynamic range is equally important to today's audio professional, and in this department BASIS hardware truly delivers: QSC engineers have given each unit a dynamic range greater than 112 dB unweighted.

Automatic Power Limiting

QSCControl.net's power limiting circuitry relies upon patented technology that limits the power driven into a loudspeaker, thereby protecting it from thermal overload. Thermal overload may result when excessive power is driven into a loudspeaker for a sufficient amount of time, causing the loudspeaker's materials to exceed their thermal limits. Within the QSCControl.net platform, the actual power driven into the loudspeakers is regulated by measuring both the voltage and current at each amplifier's output. This power limiting feature is only available on dataport-equipped BASIS models.

Introducing QSC's New Wall E-Controller

Compact, unobtrusive and featuring a look that blends well with virtually any décor, a networked wall controller adds a new dimension of versatility to QSCControl.net applications. Perfect for convention facilities, retail environments, houses of worship and a multitude of other applications, the unit can be quickly and easily programmed to build an interface that your customers will appreciate.

Just like regular PC control, multiple wall controllers can be deployed in any project and used simultaneously to manage different aspects of your system.

The QSCControl.net Solution

The QSCControl.net platform is inherently able to provide DSP, amplifier and loudspeaker management, plus CobraNet™ digital signal transport.

While it is possible to do the same thing by combining products from other manufacturers, QSCControl.net provides this capability in a single hardware unit. Fast, reliable, and featuring rock-solid performance backed by the unrivaled service and support QSC has built its reputation on, the technology of QSCControl.net brings seamless integrity to countless applications.

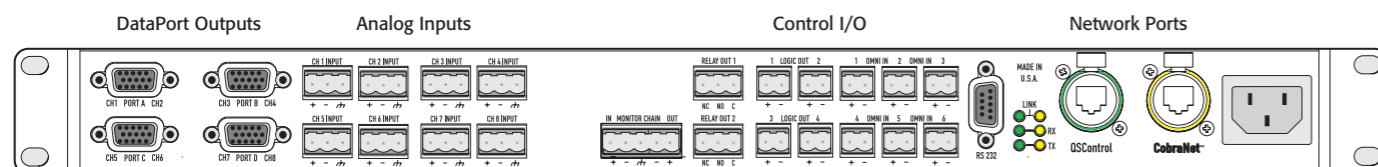

BASIS 922az pictured. The units differ by the inputs and outputs that they offer.



Call 800-854-4079 for more information today.